

## N TYPE STRAIGHT CRIMP/CRIMP PLUG 25-006-B3-AE

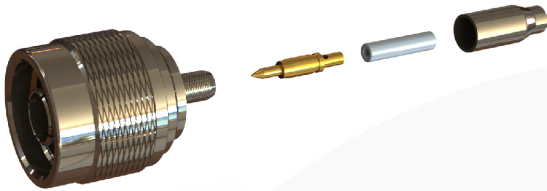

images for illustration purposes only

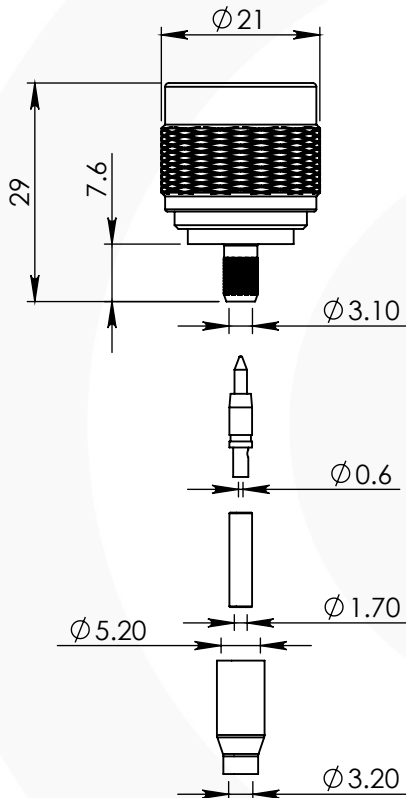

### Suitable for Cables:

(AE) RD188, RD316

### Stripping Dimensions

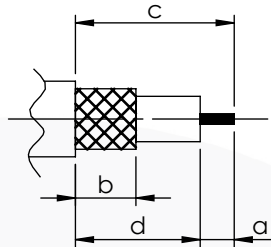

a = 4.0 mm  
b = 8.0 mm  
c = 16.0 mm  
d = 12.0 mm

### Assembly Procedure: AP001

### Tooling

Centre Contact: Hex 1.72mm A/F Tool No: 336A

Crimp Sleeve: Hex 5.41mm A/F Tool No: 336A

### Environmental Specification

Operating Temp: -55 to +155 Deg C.

IP Rating (Mated): IP 65

### Electrical Specification

Impedance: 50 Ohm

Frequency: 0-11 GHz

Dielectric W/V: 1500 Veff

Insulation res: 5000 M-Ohm

### Mechanical Specification

Contact Retention: 27 N min

Cable Retention: 150 N min

Mating cycles: 250

Weight: 36.68 g

### Connector Interface

image for illustration purposes only

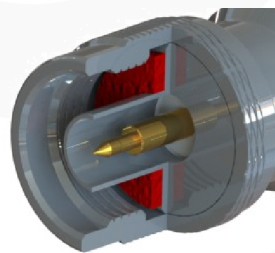

ITEM	DESCRIPTION	MATERIAL	PLATING
8	CRIMP SLEEVE	BRASS	NICKEL
7	REAR BODY	BRASS	NICKEL
6	CENTRE CONTACT	BRASS	GOLD
5	BODY	BRASS	NICKEL
4	INNER RETAINING RING	Ph Br	NICKEL
3	GASKET	SILICONE	N/A
2	INSULATOR	PTFE	N/A
1	COUPLING NUT	BRASS	NICKEL

<b>A4</b>	SHEET 1 OF 1	DIMENSIONS ARE IN MILLIMETRES		
REVISION :	B01	NAME	SIGNATURE	DATE
ISSUE :	1	DRAWN	B.S.	24/10/2017
		CHK'D	I.G.	13/02/2018
		APP'V'D		
6-8 COLNE ROAD, TWICKENHAM, MIDDLESEX. TW1 4JR				
THE INFORMATION IS GIVEN AS AN INDICATION ONLY AND IS SUBJECT TO CHANGE WITHOUT NOTICE. IN THE CONTINUAL GOAL TO IMPROVE OUR PRODUCTS, WE RESERVE THE RIGHT TO MAKE ANY MODIFICATIONS NECESSARY WITHOUT PRIOR NOTICE.				