

© 2008. THIS DOCUMENT IS THE PROPERTY OF COAX CONNECTORS LTD. REPRODUCTION OR COMMUNICATION IN ANY FORM TO A THIRD PARTY IS PROHIBITED WITHOUT PRIOR WRITTEN CONSENT

WEBSITE VIDEO No.

DO NOT SCALE DRAWING



Electrical Specification

Impedance: 50 Ohm
 Frequency: TBC
 Dielectric W/V: TBC
 Insulation res: TBC

Mechanical Specification

Centre contact retention
 Axial Force: 10N min
 Cable Retention: N/A
 Mating cycles: 500

Environmental Specification

Operating Temp: -35 to +70 Deg C

Tooling

Centre Contact: N/A
 COAX Tool No:
 Crimp Sleeve: N/A
 COAX Tool No:

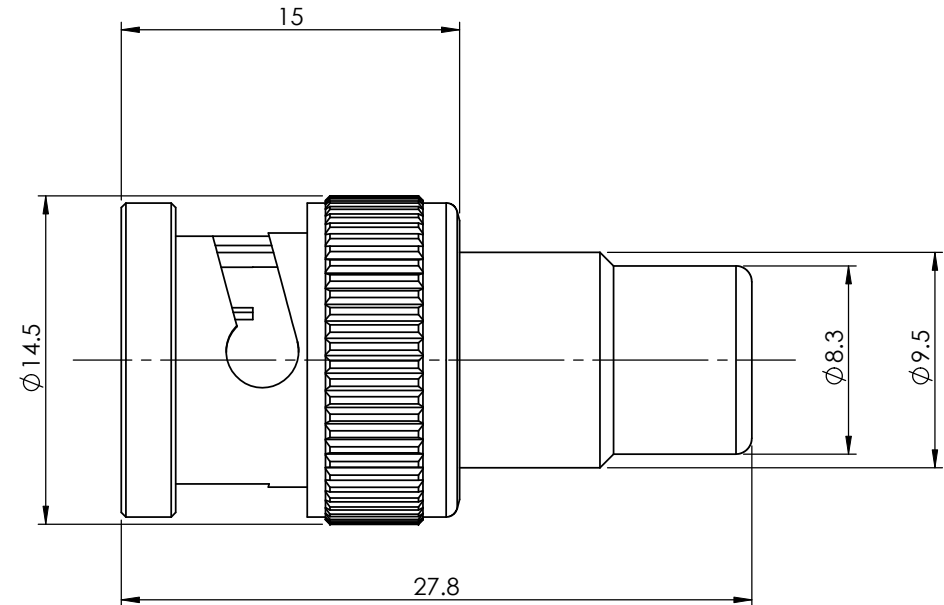
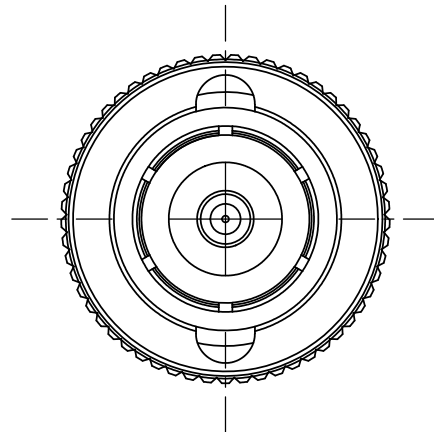

9	BODY	BRASS	NICKEL
8	INSULATOR	DELRIN	N/A
7	WASHER	Fe	NICKEL
6	SPRING	SK5	NICKEL
5	RETAINING RING	SK5	NICKEL
4	GASKET	SILICONE	N/A
3	INSULATOR	DELRIN	N/A
2	CENTRE CONTACT	BRASS	GOLD
1	COUPLING NUT	ZINC	NICKEL
ITEM	DESCRIPTION	MATERIAL	PLATING

	COAX CONNECTORS LTD 6-8 COLNE ROAD, TWICKENHAM, MIDDLESEX. TW1 4JR	REVISION : DA00 ISSUE : 1	A4 DIMENSIONS ARE IN MILLIMETERS	<table border="1"> <thead> <tr> <th>NAME</th> <th>SIGNATURE</th> <th>DATE</th> </tr> </thead> <tbody> <tr> <td>DRAWN</td> <td>GE</td> <td>28/07/2010</td> </tr> <tr> <td>CHK'D</td> <td>IG</td> <td>28/07/2010</td> </tr> <tr> <td>APPV'D</td> <td></td> <td></td> </tr> </tbody> </table>	NAME	SIGNATURE	DATE	DRAWN	GE	28/07/2010	CHK'D	IG	28/07/2010	APPV'D		
	NAME	SIGNATURE	DATE													
DRAWN	GE	28/07/2010														
CHK'D	IG	28/07/2010														
APPV'D																
Description	BNC PLUG to RCA JACK	THE INFORMATION IS GIVEN AS AN INDICATION ONLY AND IS SUBJECT TO CHANGE WITHOUT NOTICE. IN THE CONTINUAL GOAL TO IMPROVE OUR PRODUCTS, WE RESERVE THE RIGHT TO MAKE ANY MODIFICATIONS NECESSARY WITHOUT PRIOR NOTICE.														
Part Number	74-1017-511															