

## SMA STRAIGHT CRIMP/CRIMP JACK 30-054-D3-AD

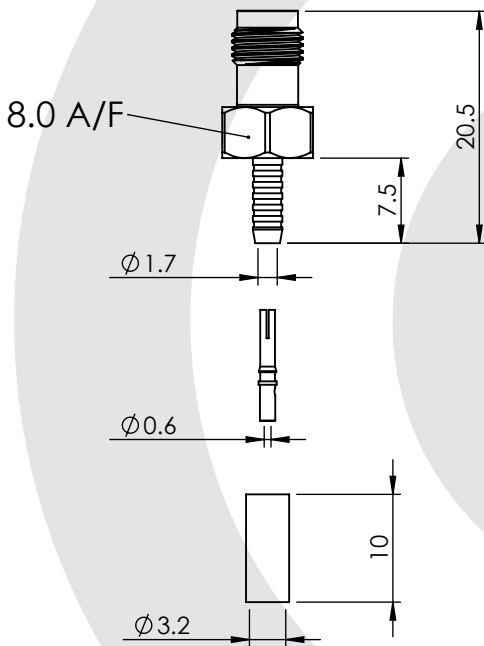

images for illustration purposes only



### Suitable for Cables:

(AD) RG316, RG174, RG188, LMR100, WBC100, URM95, KX3, KX22

### Stripping Dimensions

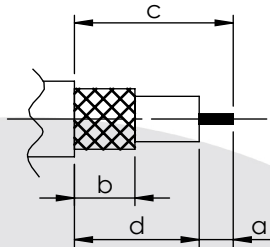

a = 3.0 mm  
b = 8.0 mm  
c = 13.0 mm  
d = 10.0 mm

### Assembly Procedure: AP001

### Tooling

Centre Contact: SQ 1.07mm A/F Tool No: 336J

Crimp Sleeve: Hex 3.25mm A/F Tool No: 336J

Alignment Tool: Not Applicable Extraction: Not Applicable

### Environmental Specification

Operating Temp: -55 to +155 Deg C.

IP Rating (Mated): IP 65

### Electrical Specification

Impedance: 50 Ohm

Frequency: 0-12 GHz

Dielectric W/V: 1000 Veff

Insulation res: 5000 M-Ohm

### Mechanical Specification

Contact Retention: 10 N min

Cable Retention: 200 N min

Mating cycles: 500

Weight: 2.94 g

### Connector Interface

image for illustration purposes only



4	CRIMP SLEEVE	BRASS	GOLD
3	INSULATOR	PTFE	N/A
2	CENTRE CONTACT	BeCu	GOLD
1	BODY	BRASS	GOLD
ITEM	DESCRIPTION	MATERIAL	PLATING

<b>A4</b>	SHEET 1 OF 1	DIMENSIONS ARE IN MILLIMETRES		
REVISION :	A01	NAME	SIGNATURE	DATE
ISSUE :	1	DRAWN	IG	12/08/2014
		CHK'D	GE	13/08/2014
		APPV'D		
6-8 COLNE ROAD, TWICKENHAM, MIDDLESEX. TW1 4JR				
THE INFORMATION IS GIVEN AS AN INDICATION ONLY AND IS SUBJECT TO CHANGE WITHOUT NOTICE. IN THE CONTINUAL GOAL TO IMPROVE OUR PRODUCTS, WE RESERVE THE RIGHT TO MAKE ANY MODIFICATIONS NECESSARY WITHOUT PRIOR NOTICE.				