

## BNC STRAIGHT CRIMP / CRIMP PLUG 10-005-B3-AN

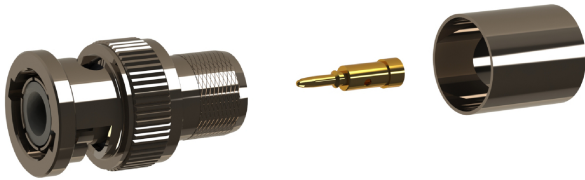

Images for illustration purposes only

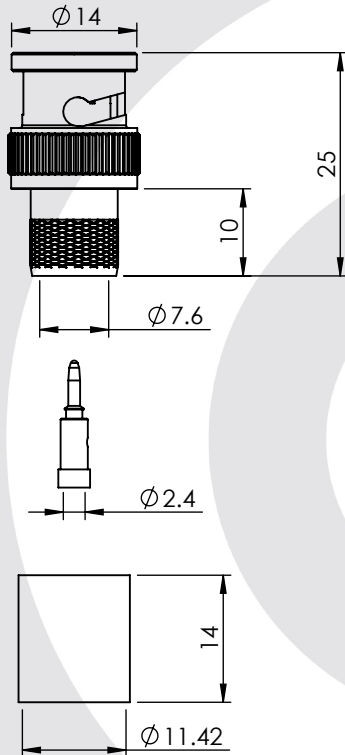

### Suitable for Cables:

(AN) RG213, URM67, KX4

### Stripping Dimensions

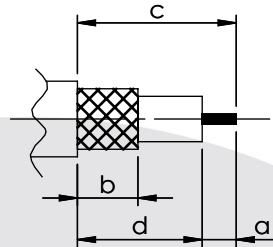

a = 5.5 mm  
b = 10.5 mm  
c = 17.0 mm  
d = 11.5 mm

### Assembly Procedure: AP001

### Tooling

Centre Contact: Hex 2.54mm A/F Tool No: 336K

Crimp Sleeve: Hex 10.9mm A/F Tool No: 336K

### Environmental Specification

Operating Temp: -55 to +155 Deg C.

IP Rating (Mated): IP 64

### Electrical Specification

Impedance: 50 Ohm

Frequency: 0-3 GHz

Dielectric W/V: 1500 Veff

Insulation res: 5000 M-Ohm

### Mechanical Specification

Contact Retention: 10 N min

Cable Retention: 150 N min

Mating cycles: 500

Weight: 14.09 g

### Connector Interface

image for illustration purposes only

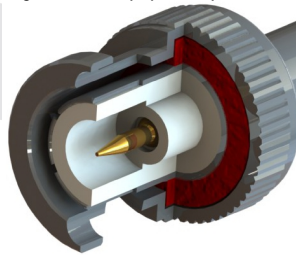

7	WASHERS	BRASS	NICKEL
6	BAYONET CAP	BRASS	NICKEL
5	GASKET	SILICONE	N/A
4	CRIMP SLEEVE	BRASS	NICKEL
3	INSULATOR	PTFE	N/A
2	CENTRE CONTACT	BRASS	GOLD
1	BODY	BRASS	NICKEL
ITEM	DESCRIPTION	MATERIAL	PLATING

<b>A4</b>	SHEET 1 OF 1	DIMENSIONS ARE IN MILLIMETRES		
REVISION :	A00	NAME	SIGNATURE	DATE
ISSUE :	1	DRAWN	IG	22/04/2015
		CHK'D	GE	23/04/2015
		APPV'D		
6-8 COLNE ROAD, TWICKENHAM, MIDDLESEX. TW1 4JR				
THE INFORMATION IS GIVEN AS AN INDICATION ONLY AND IS SUBJECT TO CHANGE WITHOUT NOTICE. IN THE CONTINUAL GOAL TO IMPROVE OUR PRODUCTS, WE RESERVE THE RIGHT TO MAKE ANY MODIFICATIONS NECESSARY WITHOUT PRIOR NOTICE.				