

TNC STRAIGHT CRIMP / CRIMP PLUG 13-005-B3-A0



Suitable for Cables:

(AN) RG213, URM67, KX4

Stripping Dimensions

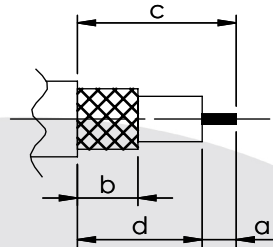

a = 5.5 mm
b = 10.5 mm
c = 17.0 mm
d = 11.5 mm

Assembly Procedure: AP001

Tooling

Centre Contact: Hex 2.54mm A/F Tool No: 336K

Crimp Sleeve: Hex 10.9mm A/F Tool No: 336K

Environmental Specification

Operating Temp: -55 to +155 Deg C.

IP Rating (Mated): IP 64

Electrical Specification

Impedance: 50 Ohm

Frequency: 0-3 GHz

Dielectric W/V: 1500 Veff

Insulation res: 5000 M-Ohm

Mechanical Specification

Contact Retention: 10 N min

Cable Retention: 150 N min

Mating cycles: 500

Weight: 16.27 g

Connector Interface

image for illustration purposes only

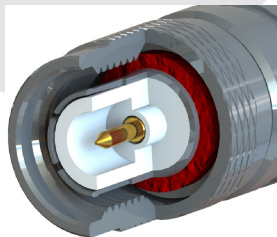

Performance

-23.3dB @ 1.0 GHz
-16.5dB @ 2.0 GHz
-12.4dB @ 3.0 GHz
-8.9dB @ 4.5 GHz

Return Loss Graph

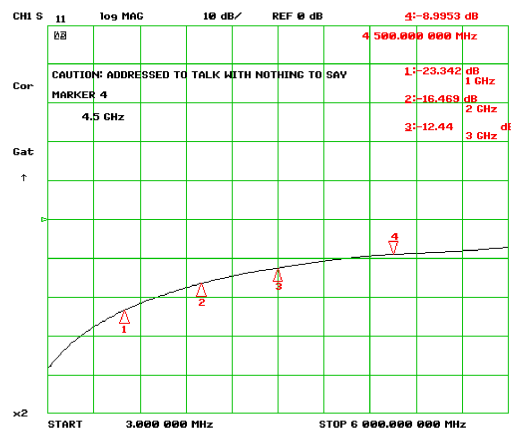

Images for illustration purposes only

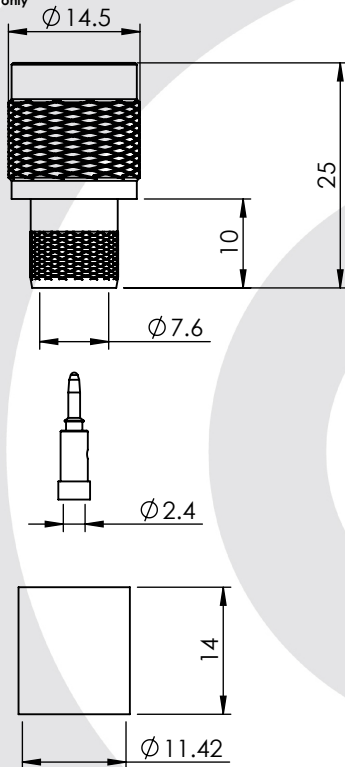

7	WASHERS	BRASS	NICKEL
6	COUPLING NUT	BRASS	NICKEL
5	GASKET	SILICONE	N/A
4	CRIMP SLEEVE	BRASS	NICKEL
3	INSULATOR	PTFE	N/A
2	CENTRE CONTACT	BRASS	GOLD
1	BODY	BRASS	NICKEL
ITEM	DESCRIPTION	MATERIAL	PLATING

A4	SHEET 1 OF 1	DIMENSIONS ARE IN MILLIMETRES		
REVISION :	A00	NAME	SIGNATURE	DATE
ISSUE :	1	DRAWN	IG	15/01/2014
		CHK'D	GE	16/01/2014
		APPV'D		
6-8 COLNE ROAD, TWICKENHAM, MIDDLESEX. TW1 4JR				
THE INFORMATION IS GIVEN AS AN INDICATION ONLY AND IS SUBJECT TO CHANGE WITHOUT NOTICE. IN THE CONTINUAL GOAL TO IMPROVE OUR PRODUCTS, WE RESERVE THE RIGHT TO MAKE ANY MODIFICATIONS NECESSARY WITHOUT PRIOR NOTICE.				