

## 10-32 STRAIGHT PCB JACK 54-452-D3

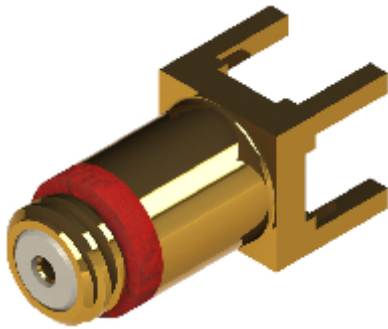

images for illustration purposes only

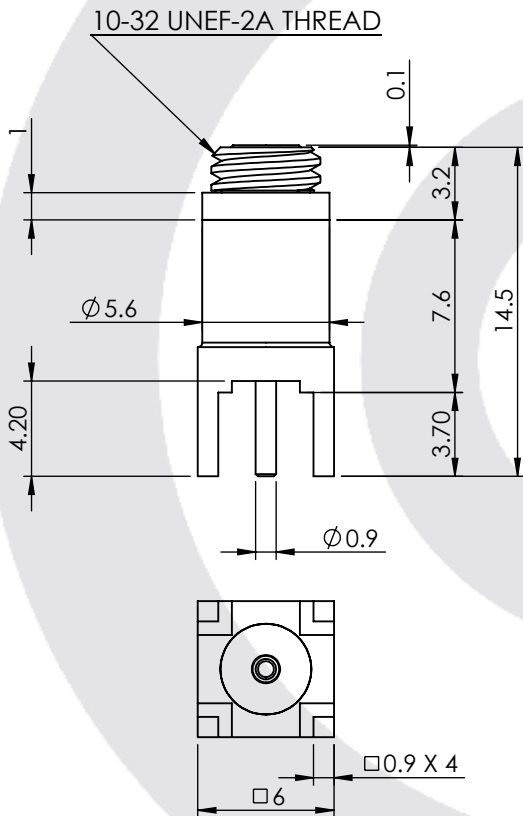

### Recommended PCB Layout

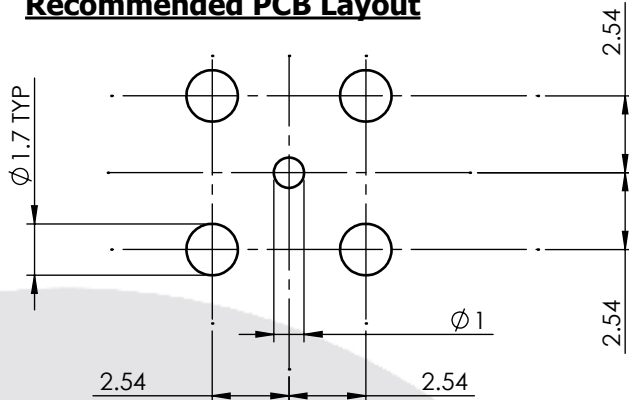

**Assembly Procedure:** Not Applicable

### Tooling

Centre Contact: Solder                      Tool No: Solder  
Crimp Sleeve: Not Applicable              Tool No: Not Applicable  
Alignment Tool: Not Applicable              Extraction: Not Applicable

### Environmental Specification

Operating Temp: -55 to +155 Deg C.  
IP Rating (Mated): IP 65

### Electrical Specification      Mechanical Specification

Impedance: 50 Ohm                      Contact Retention: 27 N min  
Frequency: 0-2 GHz                      Cable Retention: N/A N min  
Dielectric W/V: 1000 Veff                      Mating cycles: 250  
Insulation res: 5000 M-Ohm                      Weight: 2.19 g

### Connector Interface

image for illustration purposes only

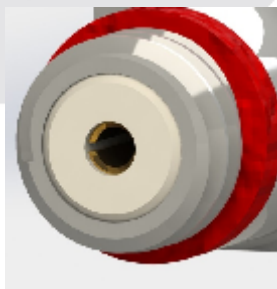

| 4    | GASKET         | SILICONE | N/A     |
|------|----------------|----------|---------|
| 3    | INSULATOR      | PTFE     | N/A     |
| 2    | CENTRE CONTACT | BeCu     | GOLD    |
| 1    | BODY           | BRASS    | GOLD    |
| ITEM | DESCRIPTION    | MATERIAL | PLATING |

|  |              |                               |           |            |
|--|--------------|-------------------------------|-----------|------------|
| <b>A4</b>  | SHEET 1 OF 1 | DIMENSIONS ARE IN MILLIMETRES |           |            |
| REVISION :   | A00          | NAME                          | SIGNATURE | DATE       |
| ISSUE :  | 1            | DRAWN                         | IG        | 04/07/2012 |
|  |              | CHK'D                         | GE        | 18/07/2012 |
|  |              | APP'V'D                       |           |            |
| <b>6-8 COLNE ROAD,<br/>TWICKENHAM,<br/>MIDDLESEX.<br/>TW1 4JR</b>  |              |                               |           |            |
| <small>THE INFORMATION IS GIVEN AS AN INDICATION ONLY AND IS SUBJECT TO CHANGE WITHOUT NOTICE. IN THE CONTINUAL GOAL TO IMPROVE OUR PRODUCTS, WE RESERVE THE RIGHT TO MAKE ANY MODIFICATIONS NECESSARY WITHOUT PRIOR NOTICE.</small> |              |                               |           |            |