

SMA STRAIGHT BULKHEAD CRIMP/CRIMP JACK

30-254-D3-AD

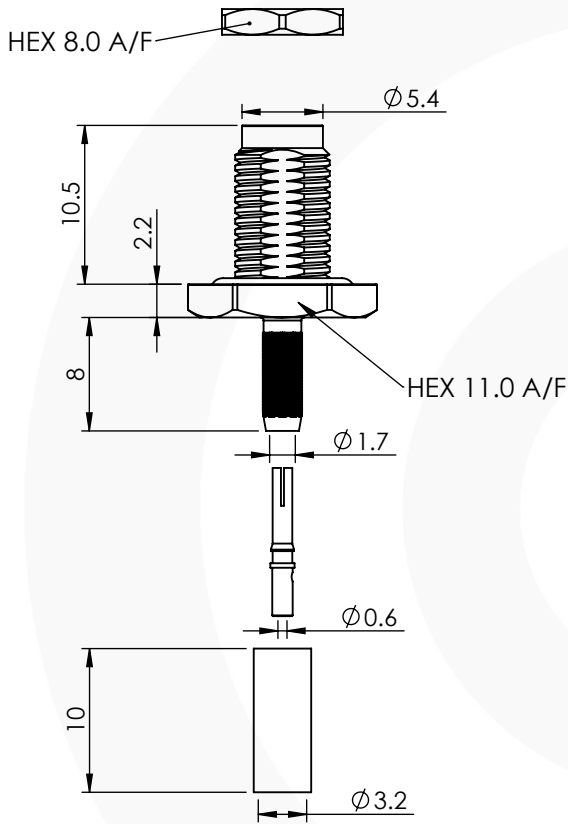
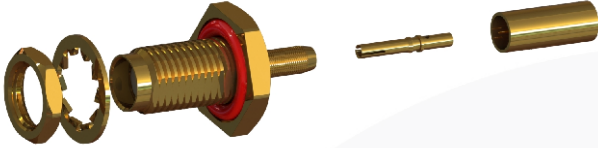

Suitable for Cables:

(AD) RG316, RG174, RG188, LMR100, WBC100, URM95, KX3, KX22

Stripping Dimensions

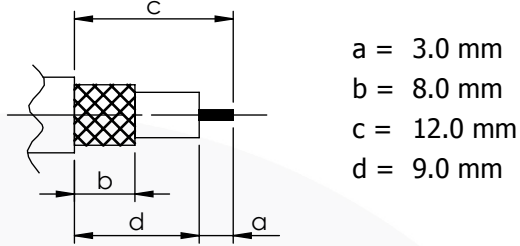

Assembly Procedure: AP001

Tooling

Centre Contact: SQ 1.07mm A/F Tool No: 336J

Crimp Sleeve: Hex 3.25mm A/F Tool No: 336J

Environmental Specification

Operating Temp: -55 to +155 Deg C.

IP Rating (Mated): IP 54

Electrical Specification Mechanical Specification

Impedance: 50 Ohm

Contact Retention: 18 N min

Frequency: 0-12 GHz

Cable Retention: 90 N min

Dielectric W/V: 750 Veff

Mating cycles: 100

Insulation res: 5000 M-Ohm

Weight: 3.75 g

Connector Interface

image for illustration purposes only



Recommended Mounting Hole

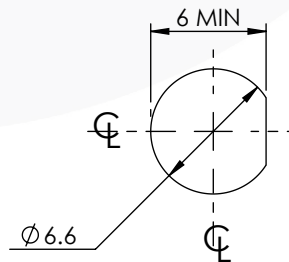

RECOMMENDED TORQUE FOR PANEL NUT : 150Ncm
 MAXIMUM PANEL THICKNESS : 6mm

7	WASHER	BeCu	GOLD
6	NUT	BRASS	GOLD
5	GASKET	SILICONE	N/A
4	CRIMP SLEEVE	BRASS	GOLD
3	INSULATOR	PTFE	N/A
2	CENTRE CONTACT	BeCu	GOLD
1	BODY	BRASS	GOLD
ITEM	DESCRIPTION	MATERIAL	PLATING

A4 SHEET 1 OF 1 DIMENSIONS ARE IN MILLIMETRES

REVISION : **A01**

NAME	SIGNATURE	DATE
DRAWN IG		09/01/2013
CHK'D GE		10/01/2013
APPV'D		

ISSUE : **2**

**6-8 COLNE ROAD,
 TWICKENHAM,
 MIDDLESEX.
 TW1 4JR**

THE INFORMATION IS GIVEN AS AN INDICATION ONLY AND IS SUBJECT TO CHANGE WITHOUT NOTICE. IN THE CONTINUAL GOAL TO IMPROVE OUR PRODUCTS, WE RESERVE THE RIGHT TO MAKE ANY MODIFICATIONS NECESSARY WITHOUT PRIOR NOTICE.