

## TNC REVERSE POLARITY BULKHEAD CRIMP / CRIMP JACK

### 14-254-A3-AH

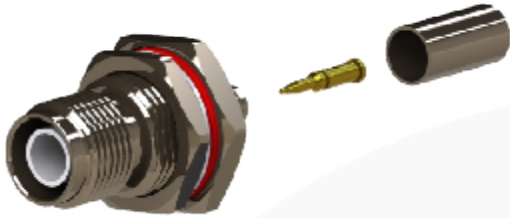

images for illustration purposes only

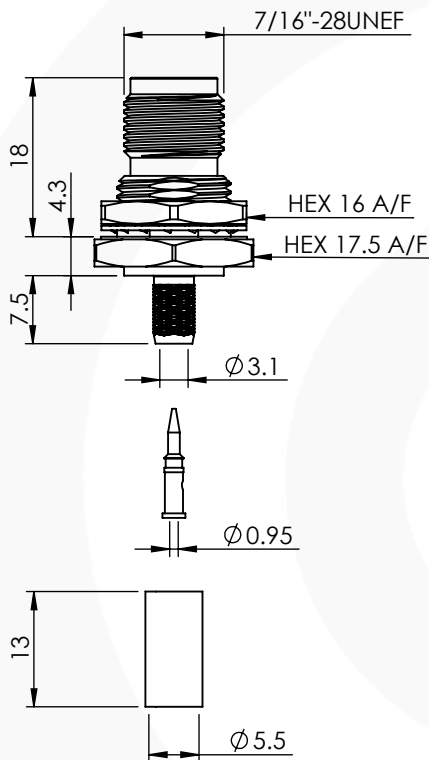

### Suitable for Cables:

(AH) RG58, RG141, LMR195, URM43, URM76, WBC195, PSF 1/6, KX15, KX23

### Stripping Dimensions

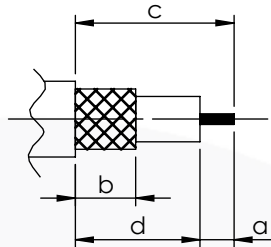

- a = 4 mm
- b = 8 mm
- c = 16 mm
- d = 12 mm

\* CUT FOIL TO DIM. "b"

### Assembly Procedure: AP001

### Tooling

Centre Contact: Hex 1.72mm A/F Tool No: 336A

Crimp Sleeve: Hex 5.41mm A/F Tool No: 336A

Alignment Tool: Not Applicable Extraction: Not Applicable

### Environmental Specification

Operating Temp: -30 to +70 Deg C.

IP Rating (Mated): IP 64

### Electrical Specification

Impedance: 50 Ohm

Frequency: 0-11 GHz

Dielectric W/V: 1500 Veff

Insulation res: 5000 M-Ohm

### Mechanical Specification

Contact Retention: 10 N min

Cable Retention: 100 N min

Mating cycles: 500

Weight: 18.49 g

### Connector Interface

image for illustration purposes only



8	GASKET	RUBBER	N/A
7	NUT	BRASS	NICKEL
6	LOCK WASHER	SK5	NICKEL
5	CRIMP SLEEVE	BRASS	NICKEL
4	INSULATOR	PTFE	N/A
3	CONTACT	BRASS	GOLD
2	RETAINER	BRASS	NICKEL
1	BODY	BRASS	NICKEL
ITEM	DESCRIPTION	MATERIAL	PLATING

<b>A4</b>	SHEET 1 OF 1	DIMENSIONS ARE IN MILLIMETRES		
REVISION :	A00	NAME	SIGNATURE	DATE
ISSUE :	1	DRAWN	BS	02/08/2017
		CHK'D	I.G.	12/09/2017
		APPV'D		
6-8 COLNE ROAD, TWICKENHAM, MIDDLESEX. TW1 4JR				
THE INFORMATION IS GIVEN AS AN INDICATION ONLY AND IS SUBJECT TO CHANGE WITHOUT NOTICE. IN THE CONTINUAL GOAL TO IMPROVE OUR PRODUCTS, WE RESERVE THE RIGHT TO MAKE ANY MODIFICATIONS NECESSARY WITHOUT PRIOR NOTICE.				