

1.0/2.3 STRAIGHT CRIMP/CRIMP PLUG 52-005-B6-FB

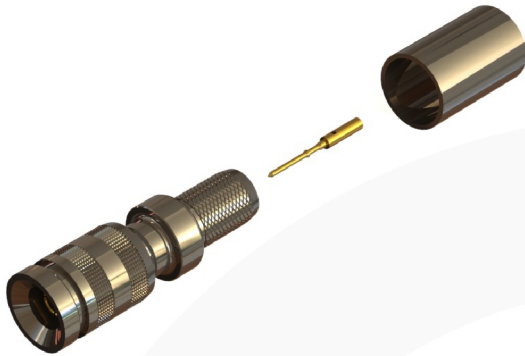

images for illustration purposes only

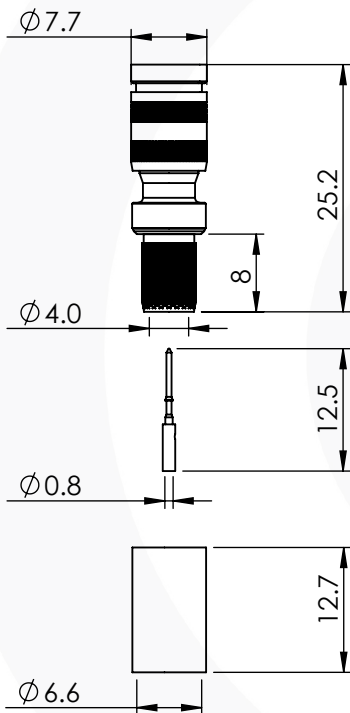

Suitable for Cables:

(FB) Belden 1505A, Draka 0.8/3.7 A/F, Image 720, Bryant BD SD05A, Condufil 14472, Percon VK6, VK66

Stripping Dimensions

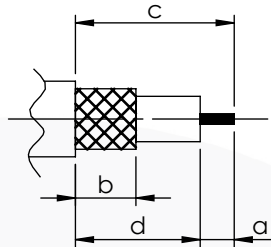

a = 4.0 mm
* b = 8.0 mm
c = 16.0 mm
d = 12.0 mm

* STRIP FOIL
SCREEN TO
DIM "b"

Assembly Procedure: AP026

Tooling

Centre Contact: SQ 0.95mm A/F Tool No: 96-HTS-76

Crimp Sleeve: HEX 6.48mm A/F Tool No: 96-HTS-76

Alignment Tool: 100-1023 Extraction: 96-1023

Environmental Specification

Operating Temp: -55 to +155 Deg C.

IP Rating (Mated): IP 40

Electrical Specification

Impedance: 75 Ohm

Frequency: 0-12 GHz

Dielectric W/V: 750 Veff

Insulation res: 5000 M-Ohm

Mechanical Specification

Contact Retention: 10 N min

Cable Retention: 150 N min

Mating cycles: 500

Weight: 5.44 g

Connector Interface

image for illustration purposes only

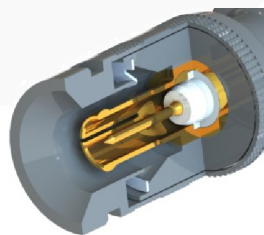

-20.08 dB @ 3.0 GHz

-25.04 dB @ 6.0 GHz

-21.96 dB @ 9.0 GHz

-12.89 dB @ 12.0GHz

Return Loss Graph

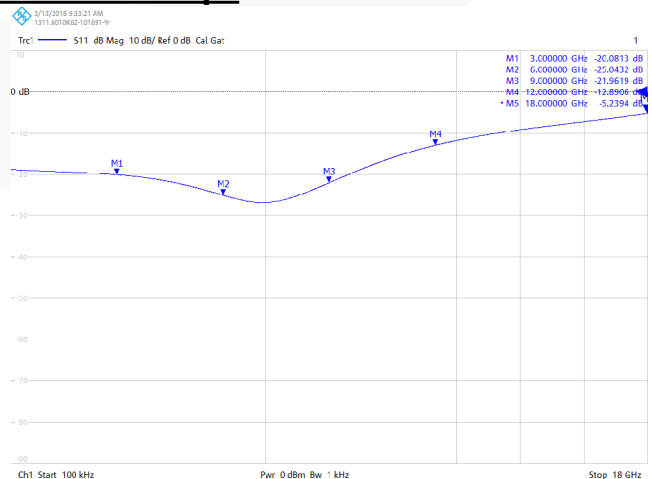

ITEM	DESCRIPTION	MATERIAL	PLATING
8	REAR BODY	BRASS	NICKEL
7	OUTER CONTACT	BERYLLIUM COPPER	GOLD
6	CENTRE CONTACT	PHOSPHOR. BRONZE	GOLD
5	SPRING	STAINLESS STEEL	NICKEL
4	CRIMP SLEEVE	BRASS	NICKEL
3	BODY	BRASS	NICKEL
2	INSULATOR	PTFE	N/A
1	COUPLING NUT	BRASS	NICKEL

A4 SHEET 1 OF 1		DIMENSIONS ARE IN MILLIMETRES		
REVISION :	B01	NAME	SIGNATURE	DATE
ISSUE :	3	DRAWN	GE	27-Nov-12
		CHK'D	IG	28-Nov-12
		APP'V'D		
<p>6-8 COLNE ROAD, TWICKENHAM, MIDDLESEX. TW1 4JR</p> <p>THE INFORMATION IS GIVEN AS AN INDICATION ONLY AND IS SUBJECT TO CHANGE WITHOUT NOTICE. IN THE CONTINUAL GOAL TO IMPROVE OUR PRODUCTS, WE RESERVE THE RIGHT TO MAKE ANY MODIFICATIONS NECESSARY WITHOUT PRIOR NOTICE.</p>				