

MICRO BNC STRAIGHT CRIMP / CRIMP JACK

67-054-B66-EF

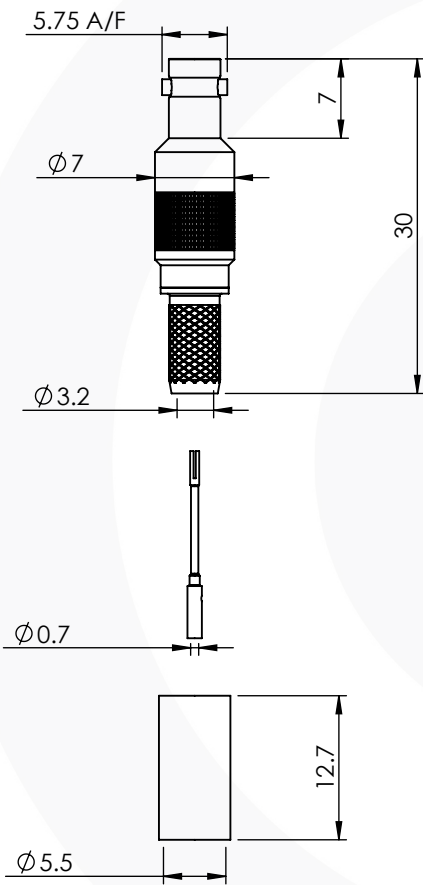
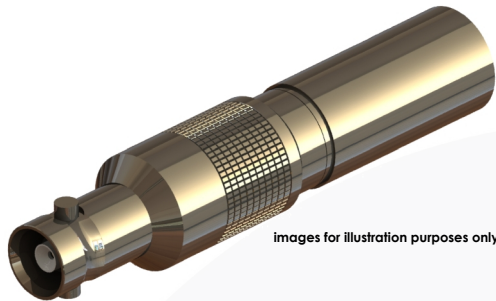

Suitable for Cables:

(EF) Belden 1855A

Stripping Dimensions

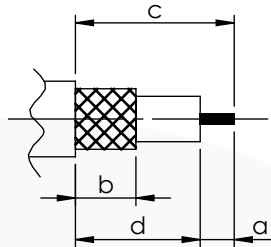

a = 4.0 mm
b = 8.0 mm
c = 16.0 mm
d = 12.0 mm

* CUT FOIL TO DIM. "b"

Assembly Procedure: AP001

Tooling

Centre Contact: SQ 0.95mm A/F Tool No:96-HTS-75

Crimp Sleeve: Hex 5.41mm A/F Tool No:96-HTS-75

Alignment Tool: Not Applicable Extraction: Not Applicable

Environmental Specification

Operating Temp: -55 to +155 Deg C.

IP Rating (Mated): IP 64

Electrical Specification Mechanical Specification

Impedance: 75 Ohm

Contact Retention: 10 N min

Frequency: 0-12 GHz

Cable Retention: 150 N min

Dielectric W/V: 1000 Veff

Mating cycles: 500

Insulation res: 10000 M-Ohm

Weight: 4.67 g

Connector Interface

image for illustration purposes only

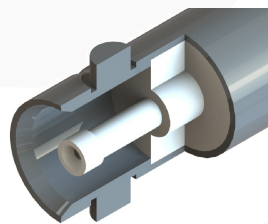

4	CRIMP SLEEVE	BRASS	NICKEL
3	INSULATOR	PTFE	N/A
2	CENTRE CONTACT	BERYLLIUM COPPER	GOLD
1	BODY	BRASS	NICKEL
ITEM	DESCRIPTION	MATERIAL	PLATING

A4	SHEET 1 OF 1	DIMENSIONS ARE IN MILLIMETRES		
REVISION :	A01	NAME	SIGNATURE	DATE
DRAWN	BS			15/06/2018
ISSUE :	1	CHK'D	I.G.	15/10/2018
		APPV'D		
6-8 COLNE ROAD, TWICKENHAM, MIDDLESEX. TW1 4JR				
THE INFORMATION IS GIVEN AS AN INDICATION ONLY AND IS SUBJECT TO CHANGE WITHOUT NOTICE. IN THE CONTINUAL GOAL TO IMPROVE OUR PRODUCTS, WE RESERVE THE RIGHT TO MAKE ANY MODIFICATIONS NECESSARY WITHOUT PRIOR NOTICE.				