

MCX STRAIGHT CRIMP/CRIMP JACK 45-054-D3-AD

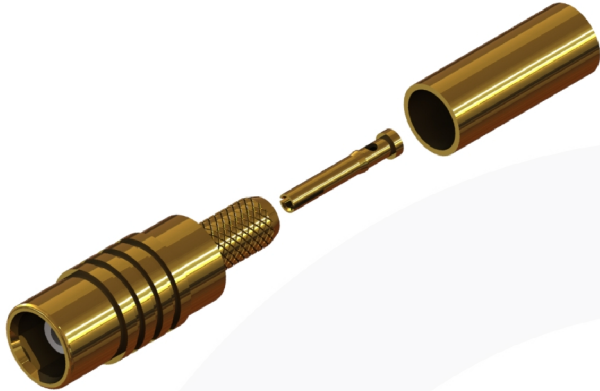

images for illustration purposes only

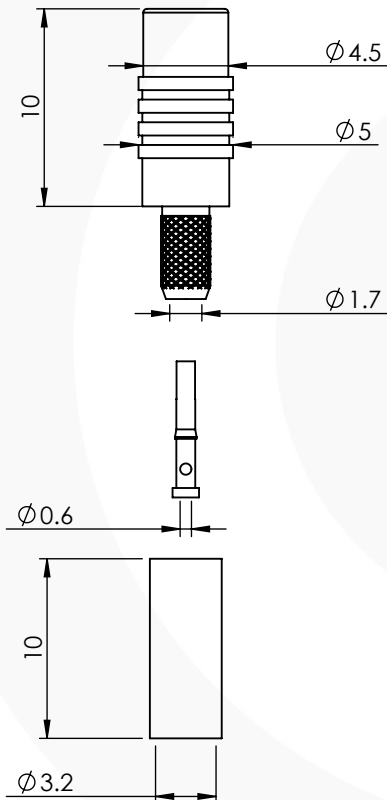

Suitable for Cables:

(AD) RG316, RG174, RG188, LMR100, WBC100, URM95, KX3, KX22

Stripping Dimensions

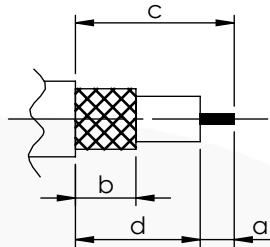

a = 2.0 mm
b = 6.0 mm
c = 9.0 mm
d = 7.0 mm

* CUT FOIL TO DIM. "b"

Assembly Procedure: AP001

Tooling

Centre Contact: 6 Tool No: DMC MH800

Crimp Sleeve: Hex 3.25mm A/F Tool No: 336J

Alignment Tool: Not Applicable Extraction: Not Applicable

Environmental Specification

Operating Temp: -55 to +155 Deg C.

IP Rating (Mated): IP 40

Electrical Specification

Impedance: 50 Ohm

Frequency: 0-6 GHz

Dielectric W/V: 500 Veff

Insulation res: 1000 M-Ohm

Mechanical Specification

Contact Retention: 10 N min

Cable Retention: 50 N min

Mating cycles: 250

Weight: 1.26 g

Connector Interface

image for illustration purposes only

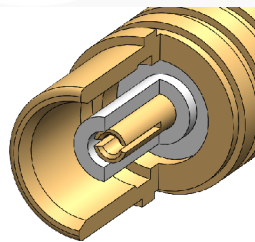

4	CRIMP SLEEVE	BRASS	GOLD
3	INSULATOR	PTFE	N/A
2	CENTRE CONTACT	BeCu	GOLD
1	BODY	BRASS	GOLD
ITEM	DESCRIPTION	MATERIAL	PLATING

A4	SHEET 1 OF 1	DIMENSIONS ARE IN MILLIMETRES		
REVISION :	A00	NAME	SIGNATURE	DATE
ISSUE :	1	DRAWN	P.P.	13/02/2020
		CHK'D	G.E.	27/02/2020
		APPV'D		
6-8 COLNE ROAD, TWICKENHAM, MIDDLESEX. TW1 4JR				
THE INFORMATION IS GIVEN AS AN INDICATION ONLY AND IS SUBJECT TO CHANGE WITHOUT NOTICE. IN THE CONTINUAL GOAL TO IMPROVE OUR PRODUCTS, WE RESERVE THE RIGHT TO MAKE ANY MODIFICATIONS NECESSARY WITHOUT PRIOR NOTICE.				