

BNC 4 HOLE FLANGE MOUNT SOLDER JACK

10-371-B3

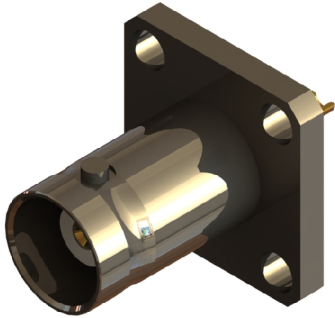

images for illustration purposes only

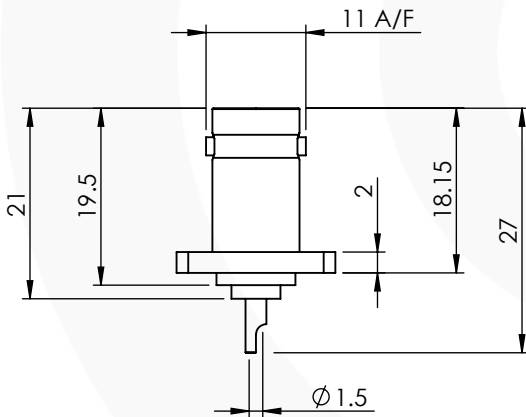
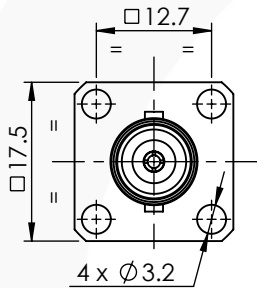

Environmental Specification

Operating Temp: -55 to +155 Deg C.

IP Rating (Mated): NONE

Electrical Specification

Impedance: 50 Ohm

Frequency: 1 GHz

Dielectric W/V: 1500 Veff

Insulation res: 5000 M-Ohm

Mechanical Specification

Contact Retention: 10 N min

Cable Retention: Not Applicable

Mating cycles: 250

Weight: 10.02 g

Connector Interface

image for illustration purposes only

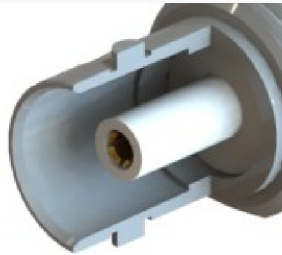

3	INSULATOR	PTFE	N/A
2	CENTRE CONTACT	PHOSPHOR BRONZE	GOLD
1	BODY	BRASS	NICKEL
ITEM	DESCRIPTION	MATERIAL	PLATING

A4	SHEET 1 OF 1	DIMENSIONS ARE IN MILLIMETRES		
REVISION :	A00	NAME	SIGNATURE	DATE
ISSUE :	1	DRAWN	G.E.	25/05/2021
		CHK'D	P.S.	25/05/2021
		APPV'D		
6-8 COLNE ROAD, TWICKENHAM, MIDDLESEX. TW1 4JR				
<small>THE INFORMATION IS GIVEN AS AN INDICATION ONLY AND IS SUBJECT TO CHANGE WITHOUT NOTICE. IN THE CONTINUAL GOAL TO IMPROVE OUR PRODUCTS, WE RESERVE THE RIGHT TO MAKE ANY MODIFICATIONS NECESSARY WITHOUT PRIOR NOTICE.</small>				