

BNC STRAIGHT CRIMP/CRIMP JACK 10-054-D126-FA

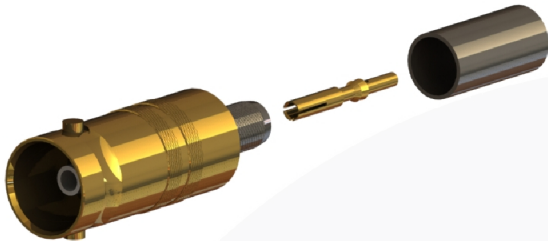

images for illustration purposes only

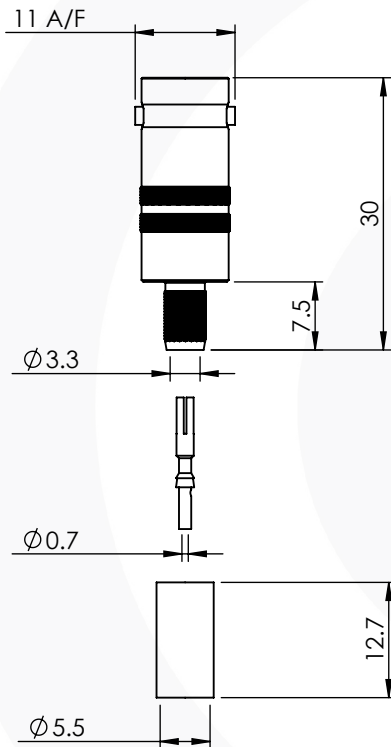

Suitable for Cables:

(FA) Belden 1855ENH, Draka0.6/2.8AF, Bryant BDD01, Image360, Condufil 9890, Percon VK5

Stripping Dimensions

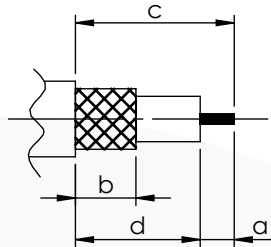

- a = 4.0 mm
- b = 8.0 mm
- c = 16.0 mm
- d = 12.0 mm

* CUT FOIL TO DIM. "b"

Assembly Procedure: AP001

Tooling

Centre Contact: SQ 1.07mm A/F Tool No: 96-HTS-75A

Crimp Sleeve: Hex 5.41mm A/F Tool No: 96-HTS-75

Alignment Tool:

Extraction:

Environmental Specification

Operating Temp: -55 to +155 Deg C.

IP Rating (Mated): IP 64

Electrical Specification

Impedance: 75 Ohm

Frequency: 0-12 GHz

Dielectric W/V: 1500 Veff

Insulation res: 5000 M-Ohm

Mechanical Specification

Contact Retention: 10 N min

Cable Retention: 150 N min

Mating cycles: 500

Weight: 8.93 g

Connector Interface

image for illustration purposes only

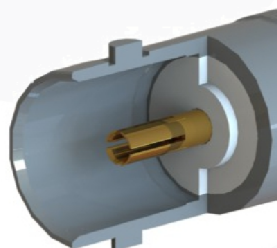

Performance

- 21.61 dB @ 3.0 GHz
- 18.56 dB @ 6.0 GHz
- 24.00 dB @ 9.0 GHz
- 28.19 dB @ 12.0 GHz
- 14.89 dB @ 18.0 GHz

Return Loss Graph

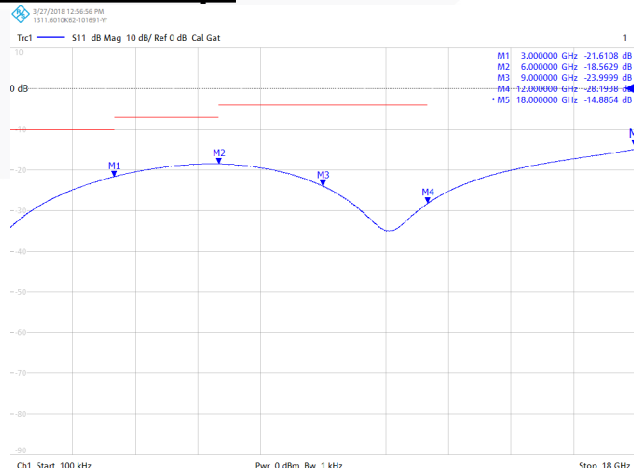

5	CRIMP SLEEVE	BRASS	NICKEL
4	REAR BODY	BRASS	NICKEL
3	CENTRE CONTACT	PHOSPHOR BRONZE	GOLD
2	INSULATOR	PTFE	N/A
1	BODY	BRASS	GOLD
ITEM	DESCRIPTION	MATERIAL	PLATING

A4	SHEET 1 OF 1	DIMENSIONS ARE IN MILLIMETRES		
REVISION :	B03	NAME	SIGNATURE	DATE
ISSUE :	4	DRAWN	I.G.	05/01/2017
		CHK'D	G.E.	06/01/2017
		APPV'D		
<p>6-8 COLNE ROAD, TWICKENHAM, MIDDLESEX. TW1 4JR</p> <p>THE INFORMATION IS GIVEN AS AN INDICATION ONLY AND IS SUBJECT TO CHANGE WITHOUT NOTICE. IN THE CONTINUAL GOAL TO IMPROVE OUR PRODUCTS, WE RESERVE THE RIGHT TO MAKE ANY MODIFICATIONS NECESSARY WITHOUT PRIOR NOTICE.</p>				